

# TJYS 移动伸缩式液压提升机

## Series Moveable & Telescopic Hydraulic Hoist Machine



TJYS系列移动伸缩式液压提升机能够与粉碎机、制粒机、混合机、压片机、胶囊填充机等主要制剂设备配套使用。能够优化生产的工艺流程，有效地杜绝了粉尘飞扬和交叉污染，减轻了劳动强度，提高了工作效率，并有效地防止了物料分层，是制药企业实现“GMP”生产的理想物料输送设备。

- 1 该机外表面采用亚光型不锈钢发纹板精制，提升臂槽进行了帘布式隔离处理，造型美观。
- 2 该机采用了电、液集成控制技术，性能稳定可靠，使用遥控器操作系统，使用方便灵活，可在任意高度自动锁定，满足生产的不同需要。
- 3 独特的伸缩式机架，可使提升机方便地在不同区域，房间与房间之间移动共用。
- 4 该机设有储油盘，杜绝了液压油泄漏而污染洁净区域。
- 5 该机液压回路有自动保压功能，即使停电，提升臂亦可保持在原来位置。
- 6 该机如一旦发生液压泄漏而降压，就会自动报警，该机会自动启动增压，保持提升臂的位置，不会损坏其他设备，确保安全生产。
- 7 产聚氨酯脚轮，可保护洁净区自流坪地面，移动灵活、轻巧。

TJYS series moveable and telescopic hydraulic hoist can be used in combination with preparation machines such as pulverizers, granulators mixers, tablet machines, cladding machines and capsule stoving machines. It can optimize technological process, effectively prevent flying dust and cross contamination, reduce labor intensity, raise working efficiency, and effectively prevent lamination of materials. It is an ideal machine for pharmaceutical plants to realize "GMP" production.

- 1 The external surface of the machine is made of stainless steel hairline plates resistant against light pollution. The lifting arm groove, treated for curtain type separation, has a fine appearance.
- 2 This machine adopts a combination of electrical and hydraulic control, and ensures a steady and reliable performance. Equipped with a rocker operating system, it is easily and flexibly operated. It can be locked automatically at any height so as to meet different requirements in the production.
- 3 A unique telescopic frame makes it possible to share the moveable hoister easily among different areas of rooms.
- 4 This machine has an oil reservoir for hydraulic leakage so that clean areas are not polluted due to hydraulic leakage.
- 5 The hydraulic loop of the machine has an automatic pressure hold function, so that even in case of power breakdown the lifting arm can still stay at its original position.
- 6 In case of pressure drop due to hydraulic leakage with the machine, there will be an automatic alarm. The machine will automatically start pressure increase and maintain the position of the lifting arm without damaging other equipment, thus ensuring safety in production.
- 7 Polyurethane caster wheels produced provide protection for the floor in the clean areas and make it easy to move the machine.

### 主要技术参数 Main Technical Specifications

参数 Parameters	型号 Model	TJYS-50	TJYS-100
最大负载 (Kg) Maximum load		50	100
最大提升高度h (mm) Maximum lifting height		2500	2500
配置料桶规格 (mm) Charging basket's specifications		Φ400 × 433	Φ500 × 527
立柱高度A (mm) Column height		2000	2000
最高点高度H (mm) Maximum height		3185	3245
电机功率 (Kw) Motor power		1.12	1.12
重量a (Kg) Weight		450	450
外形尺寸 (收缩态) mm Dimensions		1500 × 600 × 2000	1500 × 600 × 2000

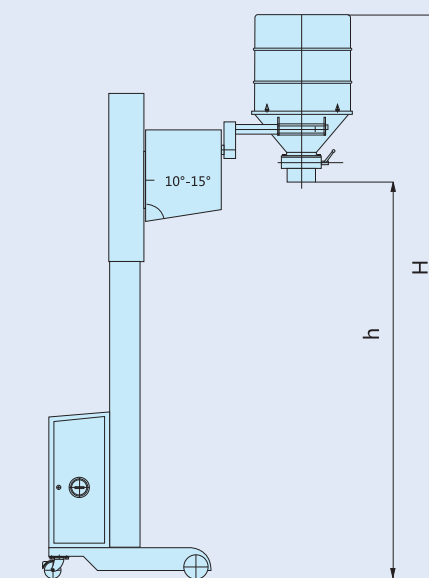

高速压片机

中速压片机

低速压片机

多功能压片机

实验室设备

压片机辅机

其它固体制剂设备